

Prepared For:
 SUPER PRODUCTS / STD CAMEL 1200
 Sales Team
 PO Box 510110
 New Berlin, WI 53151-3593
 (262)784 - 7100
 Reference ID: CAMEL1200 AUTO

Presented By:
 LAKESIDE INTL, LLC
 Todd Soczka
 11000 W SILVER SPRING RD
 MILWAUKEE WI 53225 -
 (414)353-4800

Thank you for the opportunity to provide you with the following quotation on a new International truck. I am sure the following detailed specification will meet your operational requirements, and I look forward to serving your business needs.

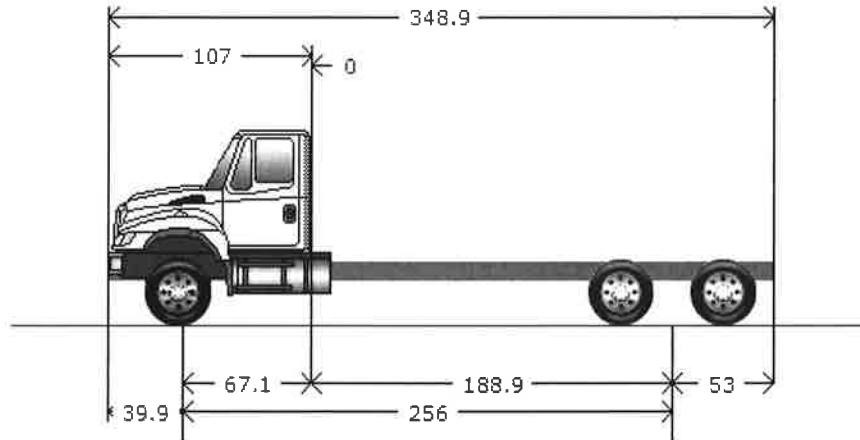

Model Profile
2019 HV607 SBA (HV607)

AXLE CONFIG:	6X4
MISSION:	Requested GVWR: 60000. Calc. GVWR: 60000 Calc. Geared Speed: 74.6 MPH
DIMENSION:	Wheelbase: 256.00, CA: 188.90, Axle to Frame: 53.00
ENGINE, DIESEL:	{Cummins L9 370} EPA 2017, 370HP @ 2000 RPM, 1250 lb-ft Torque @ 1400 RPM, 2100 RPM Governed Speed, 370 Peak HP (Max)
TRANSMISSION, AUTOMATIC:	{Allison 3000 RDS} 5th Generation Controls, Close Ratio, 6-Speed with Double Overdrive, with PTO Provision, Less Retarder, Includes Oil Level Sensor, On/Off Highway
CLUTCH:	Omit Item (Clutch & Control)
AXLE, FRONT NON-DRIVING:	{Meritor MFS-20-133A} Wide Track, I-Beam Type, 20,000-lb Capacity
AXLE, REAR, TANDEM:	{Meritor MT-40-14X-5DFR} Single Reduction, 40,000-lb Capacity, w/.5"(12.7mm) Wall Housing Thickness, R Wheel Ends Gear Ratio: 5.29
CAB:	Conventional
TIRE, FRONT:	(2) 425/65R22.5 Load Range L HTC1 (CONTINENTAL), 465 rev/mile, 68 MPH, All-Position
TIRE, REAR:	(8) 11R22.5 Load Range G HDR2 (CONTINENTAL), 491 rev/mile, 75 MPH, Drive
SUSPENSION, REAR, TANDEM:	{Hendrickson RT-403} Walking Beam Type 54" Axle Spacing; 40,000-lb Capacity with Rubber Center Bushings
FRAME REINFORCEMENT:	Outer "C" Channel, Heat Treated Alloy Steel (120,000 PSI Yield); 10.813" x 3.892" x 0.312"; (274.6mm x 98.9mm x 8.0mm); 480.0" (12192mm) Maximum OAL
PAINT:	Cab schematic 100WL Location 1: 9219, Winter White (Std) Chassis schematic N/A

<u>Code</u>	<u>Description</u>	<u>F/R Wt</u> (lbs)	<u>Tot Wt</u> (lbs)
HV60700	Base Chassis, Model HV607 SBA with 256.00 Wheelbase, 188.90 CA, and 53.00 Axle to Frame.	6403/3563	9966
1570	TOW HOOK, FRONT (2) Frame Mounted	8/0	8
1AND	AXLE CONFIGURATION {Navistar} 6x4	0/0	0
	<u>Notes</u> : Pricing may change if axle configuration is changed.		
1CBU	FRAME RAILS Heat Treated Alloy Steel (120,000 PSI Yield); 10.125" x 3.580" x 0.312" (257.2mm x 90.9mm x 8.0mm); 480.0" (12192) Maximum OAL	174/234	408
1GBP	FRAME REINFORCEMENT Outer "C" Channel, Heat Treated Alloy Steel (120,000 PSI Yield); 10.813" x 3.892" x 0.312"; (274.6mm x 98.9mm x 8.0mm); 480.0" (12192mm) Maximum OAL	522/582	1104
1LLK	BUMPER, FRONT Omit Item	-80/10	-70
1WDS	FRAME EXTENSION, FRONT Integral; 20" In Front of Grille	128/-23	105
1WGY	WHEELBASE RANGE 221" (560cm) Through and Including 262" (665cm)	0/0	0
2ARY	AXLE, FRONT NON-DRIVING {Meritor MFS-20-133A} Wide Track, I-Beam Type, 20,000-lb Capacity	186/0	186
3AGA	SUSPENSION, FRONT, SPRING Parabolic, Taper Leaf; 20,000-lb Capacity; with Shock Absorbers	58/0	58
4091	BRAKE SYSTEM, AIR Dual System for Straight Truck Applications	0/0	0
4193	BRAKES, FRONT, AIR CAM 16.5" x 6", Includes 24 SqIn Long Stroke Brake Chambers	26/0	26
4732	DRAIN VALVE {Berg} with Pull Chain, for Air Tank	0/0	0
4AZA	AIR BRAKE ABS {Bendix AntiLock Brake System} Full Vehicle Wheel Control System (4-Channel)	0/0	0
4EBD	AIR DRYER {Wabco System Saver 1200} with Heater	9/2	11
4EVH	BRAKE CHAMBERS, REAR AXLE {MGM TR3030LP3TSHD} 30/30 Spring Brake	0/82	82
4EXV	BRAKE CHAMBERS, FRONT AXLE {Bendix} 24 SqIn	18/0	18
4NDB	BRAKES, REAR, AIR CAM S-Cam; 16.5" x 7.0"; Includes 30/30 Sq.In. Long Stroke Brake Chamber and Spring Actuated Parking Brake	0/52	52
4SPA	AIR COMPRESSOR {Cummins} 18.7 CFM Capacity	0/0	0
4VKC	AIR DRYER LOCATION Mounted Inside Left Rail, Back of Cab	16/5	21
4VKK	AIR TANK LOCATION (2) Mounted Under Battery Box, Outside Right Rail, Back of Cab, Perpendicular to Rail	0/0	0
4WBX	DUST SHIELDS, FRONT BRAKE for Air Brakes	5/0	5
4WDM	DUST SHIELDS, REAR BRAKE for Air Brakes	0/12	12
5AAA	STEERING COLUMN Stationary	0/0	0
5CAW	STEERING WHEEL 4-Spoke; 18" Dia., Black	0/0	0
5PTB	STEERING GEAR (2) {Sheppard M100/M80} Dual Power	58/-3	55

<u>Code</u>	<u>Description</u>	<u>F/R Wt</u>	<u>Tot Wt</u>
		(lbs)	(lbs)
6DDA	DRIVESHAFT SYSTEM {Dana Spicer} SPL170XL with SPL170XL Interaxle Shaft in lieu of 1710 Driveshaft with 1710 Interaxle Shaft	0/0	0
7BEU	AFTERTREATMENT COVER Aluminum	9/2	11
7BKS	EXHAUST SYSTEM Single Horizontal Aftertreatment Device, Frame Mounted Right Side Under Cab; for Single Vertical Tail Pipe, Frame Mounted Right Side Back of Cab	148/29	177
7SCP	ENGINE EXHAUST BRAKE for Cummins ISB/B6.7/ISL/L9 Engine with Variable Vane Turbo Charger	0/0	0
7WBA	TAIL PIPE (1) Turnback Type, Bright, for Single Exhaust	0/0	0
7WBS	MUFFLER/TAIL PIPE GUARD (1) Bright Stainless Steel	0/0	0
7WCR	EXHAUST HEIGHT 10' 11"	2/0	2
7WZY	SWITCH, FOR EXHAUST 2 Position, Lighted & Latching, On/Off Type, Mounted in IP, Inhibits Diesel Particulate Filter Regeneration as Long as Switch is in On Position	2/0	2
8000	ELECTRICAL SYSTEM 12-Volt, Standard Equipment	0/0	0
8518	CIGAR LIGHTER Includes Ash Cup	1/0	1
8718	POWER SOURCE Cigar Type Receptacle without Plug and Cord	1/0	1
8GXD	ALTERNATOR {Leece-Neville AV1160P2013} Brush Type; 12 Volt 160 Amp. Capacity, Pad Mount, with Remote Sense	0/0	0
8HAE	BODY BUILDER WIRING Rear of Frame; Includes Sealed Connectors for Tail/ Amber Turn/Marker/ Backup/Accessory Power/Ground and Sealed Connector for Stop/Turn	0/3	3
8MJT	BATTERY SYSTEM {Fleetrite} Maintenance-Free, (2) 12-Volt 1900CCA Total	10/4	14
8NAA	TAIL LIGHT WIRING MODIFIED Includes: Wiring for Standard Lt & Rt Tail Lights; Separate 8.0' of Extra Cable Wiring for Lt & Rt Body Mounted Tail Lights	0/2	2
8RMP	RADIO AM/FM/WB/Clock/3.5MM Auxiliary Input	4/0	4
8RMY	SPEAKERS (2) 5.25" Dual Cone Mounted in Both B-Pillars	4/0	4
8VAY	HORN, ELECTRIC Disc Style	0/0	0
8VUJ	BATTERY BOX Steel with Plastic Cover, 18" Wide, 2, 3, or 4 Battery Capacity, Mounted Right Side Back of Cab	-31/8	-23
8WCK	POWER SOURCE, TERMINAL TYPE 2-Post	1/0	1
8WMA	SWITCH, TOGGLE, FOR WORK LIGHT Lighted; on Instrument Panel and Wiring Effects for Customer Furnished Back of Cab Light	2/1	3
8WPH	CLEARANCE/MARKER LIGHTS (5) {Truck Lite} Amber LED Lights, Flush Mounted on Cab or Sunshade	0/0	0
8WPZ	TEST EXTERIOR LIGHTS Pre-Trip Inspection will Cycle all Exterior Lamps Except Back-up Lights	0/0	0
8WTL	STARTING MOTOR {Delco Remy 39MT} 12 Volt; Gear Reduced, with Thermal Over-Crank Protection	12/0	12
8WWJ	INDICATOR, LOW COOLANT LEVEL with Audible Alarm	0/0	0

<u>Code</u>	<u>Description</u>	<u>F/R Wt</u> (lbs)	<u>Tot Wt</u> (lbs)
8WXD	ALARM, PARKING BRAKE Electric Horn Sounds in Repetitive Manner When Vehicle Park Brake is "NOT" Set, with Ignition "OFF" and any Door Opened	0/0	0
8XAH	CIRCUIT BREAKERS Manual-Reset (Main Panel) SAE Type III with Trip Indicators, Replaces All Fuses	0/0	0
8XGT	TURN SIGNALS, FRONT Includes LED Side Turn Lights Mounted on Fender	0/0	0
8XHD	BATTERY DISCONNECT SWITCH 300 Amp; Cab Mounted, Disconnects Charging Circuits; Locks with Padlock	2/0	2
8XHN	HORN, AIR Black, Single Trumpet, with Lanyard Pull Cord	0/0	0
8XHR	POWER SOURCE, ADDITIONAL Auxiliary Power Output (APO) & USB Port, Located in the Instrument Panel	0/0	0
9585	FENDER EXTENSIONS Rubber	6/0	6
9AAB	LOGOS EXTERIOR Model Badges	0/0	0
9AAE	LOGOS EXTERIOR, ENGINE Badges	0/0	0
9HAN	INSULATION, UNDER HOOD for Sound Abatement	10/0	10
9HBM	GRILLE Stationary, Chrome	0/0	0
9HBN	INSULATION, SPLASH PANELS for Sound Abatement	2/0	2
9WAC	BUG SCREEN Mounted Behind Grille	5/0	5
9WBC	FRONT END Tilting, Fiberglass, with Three Piece Construction; for WorkStar/HV	0/0	0
10060	PAINT SCHEMATIC, PT-1 Single Color, Design 100	0/0	0
	<u>Includes</u> : PAINT SCHEMATIC ID LETTERS "WL"		
10761	PAINT TYPE Base Coat/Clear Coat, 1-2 Tone	0/0	0
10WBS	KEYS - ALL ALIKE, ADDITIONAL 2 Keys	0/0	0
10WCY	SAFETY TRIANGLES	6/0	6
10WKN	KEYS - ALL ALIKE, ID I-1624 Compatible with Z-250	0/0	0
10WWP	MUD FLAPS, FRONT WHEELS (2) Rubber, Behind Front Wheels, Mounted on Fender Extension, for Tire Size 425/445	3/0	3
11001	CLUTCH Omit Item (Clutch & Control)	-57/-6	-63
12703	ANTI-FREEZE Red, Extended Life Coolant; To -40 Degrees F/ -40 Degrees C, Freeze Protection	0/0	0
12EHY	ENGINE, DIESEL {Cummins L9 370} EPA 2017, 370HP @ 2000 RPM, 1250 lb-ft Torque @ 1400 RPM, 2100 RPM Governed Speed, 370 Peak HP (Max)	578/-14	564
12THT	FAN DRIVE {Horton Drivemaster} Direct Drive Type, Two Speed with Residual Torque Device for Disengaged Fan Speed	0/0	0
12UWY	RADIATOR Cross Flow, Series System; 1228 SqIn Aluminum Radiator Core and 1167 SqIn Charge Air Cooler	0/0	0
12VBB	AIR CLEANER Dual Element	4/0	4
12VGN	FEDERAL EMISSIONS {Cummins L9} EPA, OBD and GHG Certified for Calendar Year 2018	0/0	0

<u>Code</u>	<u>Description</u>	<u>F/R Wt</u> (lbs)	<u>Tot Wt</u> (lbs)
12VXT	THROTTLE, HAND CONTROL Engine Speed Control; Electronic, Stationary, Variable Speed; Mounted on Steering Wheel	0/0	0
12WUL	BLOCK HEATER, ENGINE {Phillips} 120V/1000W, with "Y" Cord From Socket in Standard Location, For a Dealer Installed 120V/300W Max Oil Pan Heater	0/0	0
12WZJ	EMISSION COMPLIANCE Low NOx Idle Engine, Complies with California Clean Air Regulations; Includes "Certified Clean Idle" Decal located on Driver Door	0/0	0
12XAT	ENGINE CONTROL, REMOTE MOUNTED Provision for; Includes Wiring for Body Builder Installation of PTO Controls; with Ignition Switch Control for Cummins ISB/ B6.7 or ISL/L9 Engines	0/0	0
13AVR	TRANSMISSION, AUTOMATIC {Allison 3000 RDS} 5th Generation Controls, Close Ratio, 6-Speed with Double Overdrive, with PTO Provision, Less Retarder, Includes Oil Level Sensor, On/Off Highway	210/39	249
13WAW	OIL COOLER, AUTO TRANSMISSION {Modine} Water to Oil Type	25/0	25
13WET	TRANSMISSION SHIFT CONTROL for Column Mounted Stalk Shifter	0/0	0
13WLP	TRANSMISSION OIL Synthetic; 29 thru 42 Pints	0/0	0
13WUH	ALLISON SPARE INPUT/OUTPUT for Rugged Duty Series (RDS); Airport Refueler, Sewer Evac	0/0	0
13WYH	TRANSMISSION TCM LOCATION Located Inside Cab	0/0	0
13WYU	SHIFT CONTROL PARAMETERS Allison 3000 or 4000 Series Transmissions, 5th Generation Controls, Performance Programming	0/0	0
13XAM	PTO LOCATION Dual, Left and Right Side of Transmission	0/0	0
14GVZ	AXLE, REAR, TANDEM {Meritor MT-40-14X-5DFR} Single Reduction, 40,000-lb Capacity, w/.5"(12.7mm) Wall Housing Thickness, R Wheel Ends . Gear Ratio: 5.29	0/2132	2132
14UHD	SUSPENSION, REAR, TANDEM {Hendrickson RT-403} Walking Beam Type 54" Axle Spacing; 40,000-lb Capacity with Rubber Center Bushings	0/962	962
14WAL	SUSPENSION/REAR-AXLE IDENTITY for Meritor Tandem Rear Axles with Bar-Pin Beam Attachment Type Suspensions	0/0	0
15DYP	DEF TANK 9.5 U.S. Gal. 35.9L Capacity, Frame Mounted Outside Left Rail, Under Cab	20/2	22
15LMN	FUEL/WATER SEPARATOR {Racor 400 Series,} 12 VDC Electric Heater, Includes Pre-Heater, with Primer Pump, Includes Water-in-Fuel Sensor	0/0	0
15LMY	LOCATION FUEL/WATER SEPARATOR Mounted Outside Left Rail, 20" Back of Cab	0/0	0
15SWE	FUEL TANK Top Draw, Non-Polished Aluminum, 26" Dia, 70 US Gal (265L), Mounted Left Side, Under Cab	13/7	20
15WCS	FUEL COOLER Less Thermostat; Mounted in Front of Cooling Module	14/0	14
16030	CAB Conventional	0/0	0
16BAM	AIR CONDITIONER with Integral Heater & Defroster	56/0	56
16GDC	GAUGE CLUSTER Base Level; English with English Speedometer and Tachometer, for Air Brake Chassis, Includes Engine Coolant Temperature, Primary and Secondary Air Pressure, Fuel and DEF Gauges, Oil Pressure Gauge, Includes 3 Inch Monochromatic Text Display	0/0	0

<u>Code</u>	<u>Description</u>	<u>F/R Wt</u>	<u>Tot Wt</u>
		(lbs)	(lbs)
16HGH	GAUGE, OIL TEMP, AUTO TRANS for Allison Transmission	1/0	1
16HKT	IP CLUSTER DISPLAY On Board Diagnostics Display of Fault Codes in Gauge Cluster	0/0	0
16JNV	SEAT, DRIVER {National 2000} Air Suspension, High Back with Integral Headrest, Cloth, Isolator, 1 Chamber Lumbar, 2 Position Front Cushion Adjust, -3 to +14 Degree Back Angle Adjust	31/8	39
16SEE	GRAB HANDLE Chrome; Towel Bar Type with Anti-Slip Rubber Inserts; for Cab Entry Mounted Left Side Only at "B" Pillar	3/0	3
16SMM	SEAT, PASSENGER {National} Non Suspension, High Back, Fixed Back, Integral Headrest, Cloth	18/5	23
16SNM	MIRRORS (2) Thermostatically Controlled Heated Heads, Black Heads, Brackets and Arms, 7.55" x 14.1" Flat Glass, 7.48" x 6.77" Convex Glass Both Sides	0/0	0
16VKB	CAB INTERIOR TRIM Classic, for Day Cab <u>Includes</u> : CONSOLE, OVERHEAD Molded Plastic with Dual Storage Pockets, Retainer Nets and CB Radio Pocket; Located Above Driver and Passenger : DOME LIGHT, CAB Door Activated and Push On-Off at Light Lens, Timed Theater Dimming, Integral to Overhead Console, Center Mounted : SUN VISOR (2) Padded Vinyl; 2 Moveable (Front-to-Side) Primary Visors, Driver Side with Toll Ticket Strap	0/0	0
16VZB	SEAT BELT COMFORT CLIP	0/0	0
16WLS	FRESH AIR FILTER Attached to Air Intake Cover on Cowl Tray in Front of Windshield Under Hood	0/0	0
16WSK	CAB REAR SUSPENSION Air Bag Type	0/0	0
16XCK	WINDOW, MANUAL (2) and Manual Door Locks, Left and Right Doors	0/0	0
16XJN	INSTRUMENT PANEL Flat Panel	0/0	0
16ZBT	ACCESS, CAB Steel, Driver & Passenger Sides, Two Steps Per Door, for use with Regular and Extended Cabs	0/0	0
27DBA	WHEELS, FRONT {Accuride 29374} DISC; 22.5x12.25 Rims, Polished Aluminum, 10-Stud, 285.75mm BC, Hub-Piloted, Flanged Nut, with Steel Hubs	-10/0	-10
28DUW	WHEELS, REAR {Accuride 51408} DUAL DISC; 22.5x8.25 Rims, Powder Coat Steel, 2-Hand Hole, 10-Stud, 285.75mm BC, Hub-Piloted, Flanged Nut, with Steel Hubs	0/-40	-40
7372135423	(8) TIRE, REAR 11R22.5 Load Range G HDR2 (CONTINENTAL), 491 rev/mile, 75 MPH, Drive	0/120	120
7752665412	(2) TIRE, FRONT 425/65R22.5 Load Range L HTC1 (CONTINENTAL), 465 rev/mile, 68 MPH, All-Position	124/0	124
OBD001	MISCELLANEOUS Super Products Camel Frame Piercing (will delay production on initial orders) Cab schematic 100WL Location 1: 9219, Winter White (Std) Chassis schematic N/A	0/0	0

<u>Code</u>	<u>Description</u>	<u>F/R Wt</u> (lbs)	<u>Tot Wt</u> (lbs)
Services Section:			
40128	WARRANTY Standard for HV507, HV50B, HV607 Models, Effective with Vehicles Built July 1, 2017 or Later, CTS-2025A	0/0	0
40KMA	SERVICES, TOWING (Navistar) Service Call to 24-Month/Unlimited Mileage to the Nearest Navistar Dealer for Navistar Warrantable Failure as Contract Defined; Includes Engine Failure if Supplier Declines Tow Coverage & ESC Supplied thru Navistar; \$550 (USA) Maximum Benefit per Incident	0/0	0
Total Component Weight:		8760/7780	16540
	Fire ext. and Triangles	0/0	0
	\$100 of fuel	0/0	0
Total Goods Purchased:		0/0	0

The weight calculations included in this proposal are an estimate of future vehicle weight. The actual weight as manufactured may be different from the estimated weight. Navistar, Inc. shall not be liable for any consequences resulting from any differences between the estimated weight of a vehicle and the actual weight.

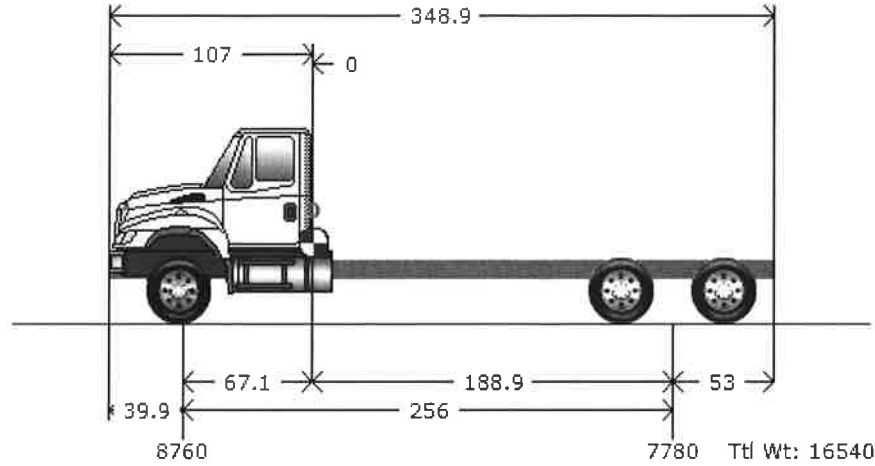

Graphics are provided as visual aids only and are not intended to represent the actual scale, shape, or color of the truck or its components. All weights are represented in lbs.

Truck		Body/Trailer			Chassis/Empty Weights	
Bumper to Axle	(BA) 39.9	Body Length	(BL)	N/A	Tractor Front Axle:	8,760
Wheelbase	(WB) 256.00				Tractor Rear Axle:	7,780
Axle to Frame	(AF) 53.00					
Axle to Back Cab	(ABC) 67.1					
Cab to Axle	(CA) 188.9					
Usable CA	188.9					
CA Reduction Adjustment	0.00					
Fuel-Diesel(Gals)	0					
DEF(Gals)	0					

Before the Cab			Cab			Payloads Chassis			Body		After the Body			
#	Weight	CG	#	Weight	CG	#	Weight	CG	#	Weight	CG	#	Weight	CG
						1	0	1						

Loads	
Payload Weight:	0
Driver:	0
Fuel-Diesel(Lbs):	0
DEF(Lbs):	0

Weight Distribution	
Total Front Axle:	8,760
Total Rear Axle:	7,780
Total Weight:	16,540

Weights and clearances in this proposal are estimates only. Navistar, Inc. is not liable for any consequences resulting from any differences between the estimated weights and clearances and the actual manufactured weights and clearances.

Weight Distribution

All weights are represented in lbs.

	Truck		
	Front	Rear	Total
<u>Chassis Weight</u>			
Chassis Weight:	8,760	7,780	16,540
Fuel:	0	0	0
DEF:	0	0	0
	(Curb Weight): 8,760	7,780	16,540

Loads

Payloads:	0	0	0
Driver:	0	0	0
	Axle Totals (Gross Weight): 8,760	7,780	16,540

Weight Ratings

	Truck	
	Front	Rear
Axle(axle capacity)	20,000	40,000
Tire(tire capacity)	22,800	24,700
Suspension(suspension capacity)	20,000	40,000
Spring:	0	
Fed Bridge Law (axle spread):	20,000	34,000 (54")
Wheel Combination	Load	Limit
1 - 3	16,540	53,000

Federal Total Vehicle Weight Limit: 80,000

Maximum Gross Vehicle Weight Rating (GVWR) 60,000 - Gross Vehicle Weight(GVW) 16,540 = 43,460 Reserves

Weight Summary

* Distributed weights are within capacity limits

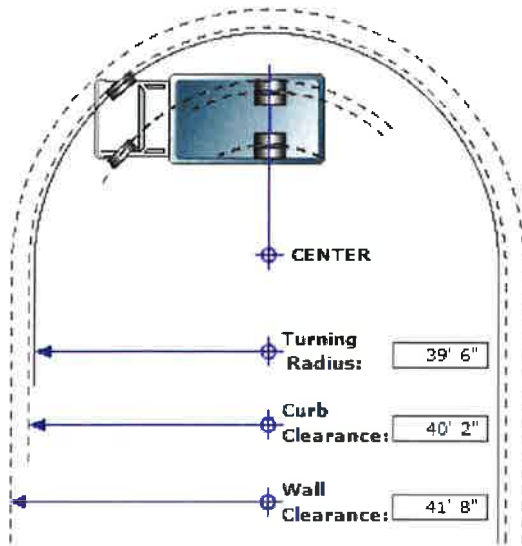

Series: HV
 Model: HV607
 Description: HV607 SBA
 Model Year: 2019

Calculation Factors

Wheelbase: 256
 Front Axle: 0002ARY
 Description: AXLE, FRONT NON-DRIVING, {Meritor MFS-20-133A} Wide Track, I-Beam Type, 20,000-lb Capacity
 Front Wheel: 0027DBA
 Description: WHEELS, FRONT, {Accuride 29374} DISC; 22.5x12.25 Rims, Polished Aluminum, 10-Stud, 285.75mm BC, Hub-Piloted, Flanged Nut, with Steel Hubs
 Front Tire: 07752665412
 Description: TIRES, 425/65R22.5 Load Range L HTC1 (CONTINENTAL), 465 rev/mile, 68 MPH, All-Position
 Steering Gear: 0005PTB
 Description: STEERING GEAR, (2) {Sheppard M100/M80} Dual Power

Turning Radius Statistics

General Information

Inside Turn Angle: 39 Degrees
 Radial Overhang: 26

Axle Information

KingPin Inclination: 6.25 Degrees
 KingPin Center: 71

Turning Radius - Curb View

C - Curb Contact Length: 16.96
 CI - Curb Clearance Increment: 8.60
 CR - Curb Clearance Radius: 40'2"
 CH - Curb Height: 6"
 TR - Turning Radius: 39'6"
 TW - Tire Width: 16.60

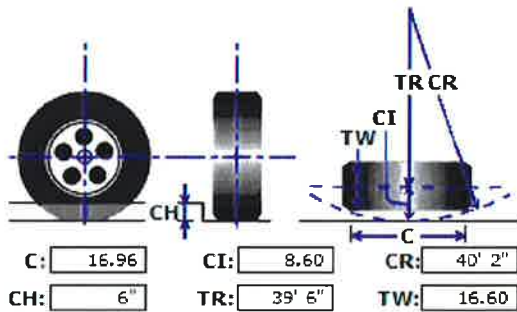

* All Measurements are in inches, unless otherwise specified.

This information is based on engineering information available at this time. Actual figures may vary. Navistar, Inc. cannot accept liability for consequences due to this variance.